

ПРЕДПРИЯТИЕ МАКСАЭРО

- Производство воздуховодов и систем вентиляции
- Клапаны противопожарные
- Клапаны дымоудаления
- Вентиляторы общепром, дымоудаления, крышные

220056, г. Минск, ул. Стариновская, 15

Тел./факс: +375 17 244-67-44, 258-67-51, 347-73-56, 252-54-27

Velcom: +375 29 603-88-99

E-mail: olegaero@yandex.by

www.maxaero.by



Мембранные пневматические насосы Debem Boxer



Boxer diaphragm pumps:
high performance, high power and sturdiness.

Suitable for pumping fluids with high apparent viscosity, even in the presence of suspended solids.



PUMPS COMPOSITION CODES

BOXER

ex. **IB50-P-HTTPV--**

Internal Exchanger, Boxer 50, body PP, air side diaphragm Hytrel, fluid side diaphragm PTFE, balls PTFE, ball seats PP, O-Ring in Viton.

<u>I</u>	<u>B50</u>	<u>P</u>	<u>H</u>	<u>T</u>	<u>T</u>	<u>P</u>	<u>V</u>	<u>-</u>	<u>-</u>
Internal Exchanger	Pump model	Pump body	Air side diaphragm	Fluid side diaphragm	Balls	Ball seats*	O-Ring**	Twin manifold	Conduct version
I	MICR - Microboxer ¹ MIN - Miniboxer ² B50 - Boxer 50 ³ B80 - Boxer 80 ⁴ B81 - Boxer 81 ⁵ B100 - Boxer 100 B150 - Boxer 150 B251 - Boxer 251 B502 - Boxer 502 ⁶ B522 - Boxer 522 ⁷ B503 - Boxer 503	P - PP PC - PP + CF FC - PVDF + CF AL - ALU A - AISI 316	H - Hytrel M - Santoprene D - EPDM N - NBR	T - PTFE	T - PTFE A - AISI 316 D - EPDM N - NBR	P - Polypropylene F - PVDF A - AISI 316 L - Aluminium I - PE-UHMW R - PPS-V (only for BOXER 100 and BOXER 150)	T - PTFE D - EPDM V - Viton N - NBR	X	C

¹ MICROBOXER only mounts internal membranes in HYTREL / SANTOPRENE

² MINIBOXER inscription only on body in AISI 316

³ BOXER50 inscription only on body in PP - PP+CF - PVDF - ALU

⁴ BOXER80 inscription only on body in AISI 316

⁵ BOXER81 inscription only on body in PP - PP+CF - PVDF - ALU

⁶ BOXER502 inscription only on body in ALU - AISI 316

⁷ BOXER522 inscription only on body in PP - PP+CF - PVDF

* BOXER100/BOXER150 only mounts ball seats in PPS-V, not in aluminium

** BOXER503 in plastic cannot mount O-rings in PTFE, only in VITON or EPDM

MAIN FEATURES:

Available in PP, PVDF, ALUMINIUM and AISI 316 STAINLESS STEEL;

Use in potentially-explosive atmospheres (ATEX zone 1-2 certification);

Suitable for demanding applications and high-humidity environments;

Dry operation;

Dry self-priming;

Actuated using non-lubricated air;

Stall-prevention pneumatic circuit;

Adjustable flow rate and head;

Fine tuning of motor speed at constant pressure;
Twin-manifold option
 (two suction and two delivery);

Bench or ceiling installation;

Three suction and delivery positions;

User-friendly maintenance and parts replacement;

Excellent performance and value for money.

Max. operating temperature:

PP min +3°C/max +65°C

PVDF min +3°C/max +95°C

Aisi 316 min +3°C/max +95°C

Alu min +3°C/max +95°C

BOXER diaphragm pumps are characterized by exceptional performance, power and strength, making them ideal for pumping liquids with high apparent viscosity even if containing suspended solids.

The **stall-prevention** pneumatic system assures a safe pump running and it does **not need lubricated air**.

Self-priming dry capacity even with considerable suction head, **fine tuning of speed** without pressure loss and the **possibility of dry operation without suffering damage** mean that these pumps offer unrivalled versatility. In addition, the huge choice of construction materials allows selection of optimum chemical compatibility with the fluid and/or environment without neglecting the temperature range. They are specifically designed for **demanding applications with high humidity or in potentially explosive atmospheres (ATEX certification)**.

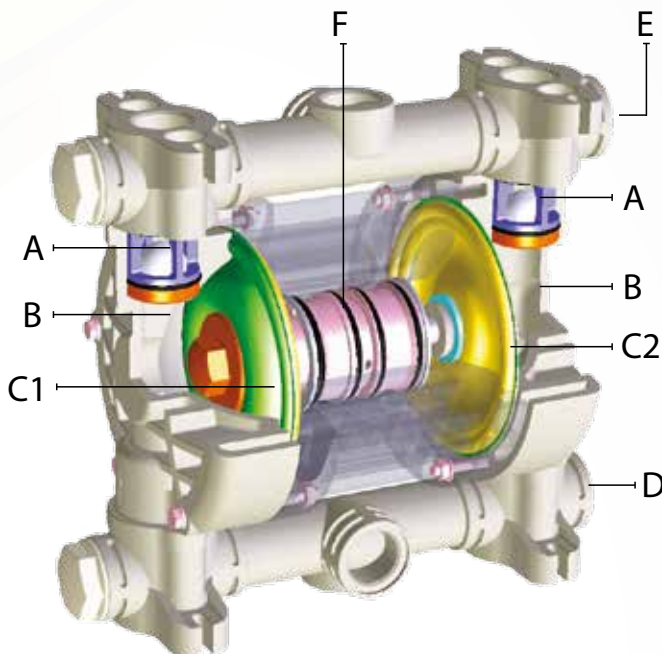

- A** = ball valves
- B** = pumping chamber
- C1** = product-side diaphragm
- C2** = air-side diaphragm
- D** = suction manifold
- E** = delivery manifold
- F** = pneumatic exchangers

BOXER



BOXER PLASTIC

Ex II 2/2GD c IIB T135°C (zona 1)
II 3/3GD c IIB T135°C (zona 2)

The plastic BOXER range is designed for the chemical industry's most demanding applications including highly-aggressive liquids and acids.

Materials: **PP - PVDF**
Self-priming capacity: **max 6m**
Max. head: **70m**
Max. flow rate: **30 ÷ 900 l/min**



BOXER METAL

Ex II 2/2GD c IIB T135°C (zona 1)
II 3/3GD c IIB T135°C (zona 2)

The metal BOXER range is designed for demanding applications throughout the paint sector and for solvent-based liquids.

Materials: **Alu - AISI 316**
Self-priming capacity: **max 6m**
Max. head: **70m**
Max. flow rate: **30 ÷ 900 l/min**



DIAPHRAGM PUMPS

HOW IT WORKS

The compressed air introduced by the pneumatic exchanger (A) behind one of the two diaphragms generates compression and pushes the product into the delivery duct (B), at the same time the opposing diaphragm that is integral with the exchanger shaft creates a vacuum and intakes the fluid (C). Once the stroke has been completed, the pneumatic exchanger diverts the compressed air behind the opposing diaphragm and the cycle is reversed.

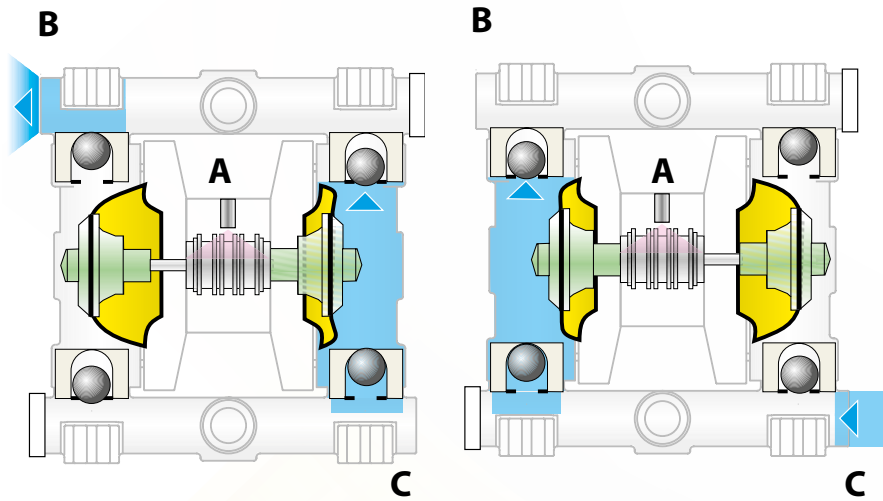

INSTALLATION

The pumps **must be installed vertically** with special bolts on the feet or holes provided.

Self-priming

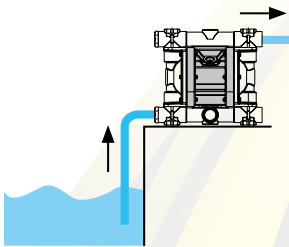

Drum transfer

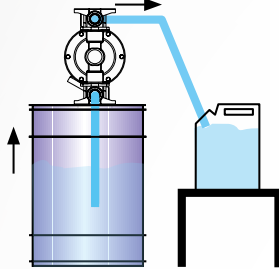

Positive suction head

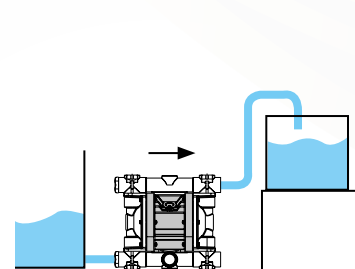

Immersed

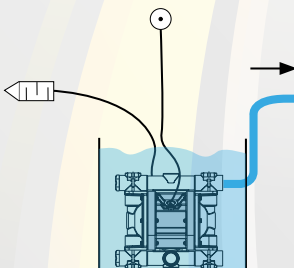

Twin suction and delivery manifold

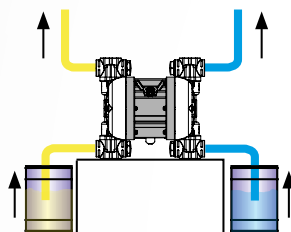

Twin suction manifold

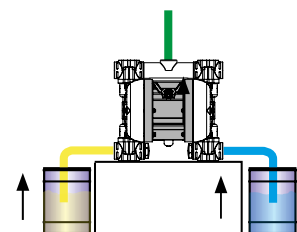

PNEUMATIC EXCHANGERS

The heart of an air-operated diaphragm pump consists of the pneumatic exchanger that DEBEM has succeeded in developing and innovating in a revolutionary manner, patenting the most durable and reliable system the market currently has to offer. This device introduces compressed air to alter the pressure balance of the diaphragms assisted by a stall-prevention circuit that ensures optimum performance even under the most critical conditions or with low-pressure compressed air supplies (min 2 bar).

Air-chamber volumes and airways are carefully designed to optimise consumption.

Speed and flow rate can be easily adjusted by regulating air flow, whilst head can be adjusted as a function of compressed air supply pressure.

THE COMPONENTS

It has an extremely compact footprint and the small number of components ensures exceptional sturdiness and service life even under the most exacting conditions.

The air passages are carefully designed and optimised to prevent the formation of ice even in low-temperature and high-head applications.

The DEBEM pneumatic exchanger is an integrated system with a single central cartridge that does not require additional external components.

DEBEM DIAPHRAGMS

Diaphragms are the components subjected to greatest stress during suction and pumping, when they must also withstand the liquid's chemical attack and temperature.

Correct assessment and selection is therefore crucial for diaphragm service life, investment decisions and maintenance costs.

A modern process of design, destructive testing and careful analysis of results has enabled DEBEM to develop LONG LIFE new generation diaphragms. The shape and profile of these products provides a greater working surface and improved load redistribution, thus reducing material stress and yield to a minimum.

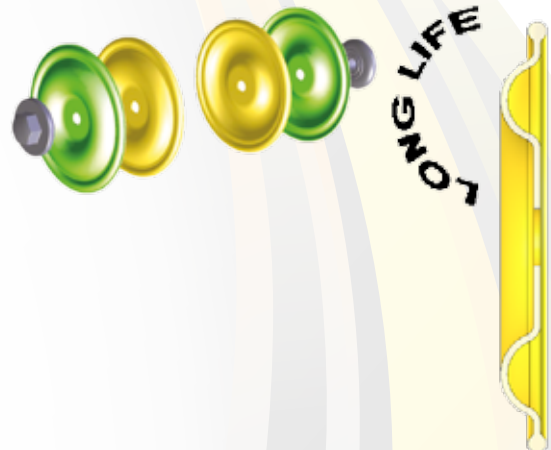

BOXER

RUBBER DIAPHRAGMS

They are made from rubber compounds with special additives that improve chemical properties as well as mechanical bending and strength characteristics. These diaphragms have a nylon backing cloth that improves stress distribution:

NBR: inexpensive and particularly suited to petroleum- and oil-based liquids;

EPDM: good acid, alkaline and abrasion resistance, as well as good flexibility even at low temperatures.

NBR



EPDM



THERMOPLASTIC DIAPHRAGM

They are made from thermoplastic polymers that provide high mechanical stress resistance and distribution.

HYTREL:

exceptional strength and elastic return; high resistance to creeping, impact and stress when flexed; excellent flexibility at low temperatures, while maintaining most of its properties at high temperatures. It is also resistant to the attack of many industrial chemicals, oils and solvents;

SANTOPRENE®:

excellent acid and alkaline resistance, high flexural strength and good abrasion resistance.

HYTREL



SANTOPRENE



PTFE DIAPHRAGM

This material is noted for its excellent resistance to high temperatures, chemicals and corrosive agents. DEBEM PTFE diaphragms are subjected to a double heat treatment in order to increase elasticity and service life. Each batch undergoes random destructive testing in order to verify its performance.

This diaphragm can be fitted together with one of those previously mentioned in order to increase resistance to the liquid's corrosive chemicals and temperature.

PTFE





Debem has filed with the **TÜV NORD** certification body the documentation certifying **ATEX** compliance pursuant to Directive 94/9/CE for its ranges of **BOXER** and **CUBIC** pneumatic diaphragm pumps and **EQUAFLUX** automatic pulsation dampeners, as described in the following table.

They are manufactured in a **STANDARD**, class **II 3/3GD c IIB T135°C** version or - upon request - with special construction materials in a **CONDUCT**, class **II 2/2GD c IIB T135°C** version.

The equipment user is responsible for classifying its area of use. On the other hand, the manufacturer shall identify and affix the certification class of the manufactured equipment.



SERIE PRODOTTI	DESCRIZIONE	CLASSE DI CERTIFICAZIONE
versione STANDARD - CUBIC - BOXER - FOODBOXER - EQUAFLUX	Costruite in materiale plastico non conduttivo e/o con corpo centrale non conduttivo, oppure in materiale metallico con corpo centrale non conduttivo.	 II 3/3 GD c IIB T135°C (per zona 2)
versione CONDUCT - CUBIC - BOXER - FOODBOXER - EQUAFLUX	Costruite con corpi pompa e/o collettori in materiali plastici conduttivi (PP + Fibra di carbonio, ECTFE/PVDF + Fibra di carbonio), e materiali metallici (Alluminio, Acciaio Inox).	 II 2/2 GD c IIB T135°C (per zona 1)

 Safety symbols in accordance with DIN 40012 Annex A

II 2/2 GD: Surface equipment for use in zones in which gases, vapours or mists and clouds of combustible dust in air occur in normal operation occasionally (EN 1127-1 subclause 6.3) in both the external and internal zone.

II 3/3 GD: Surface equipment for use in zones in which gases, vapours or mists and clouds of combustible dust in air are not likely to occur in normal operation or may occur rarely for a short period only in both the external and internal zone.

c: Equipment protected by constructional safety (EN 13463-5).

IIB: Exclusion of the following products: Hydrogen, acetylene, carbon disulphide.

T 135°: Allowed temperature class. The user shall process fluids in accordance with the corresponding temperature classification, bearing in mind the instructions in the manual and the provisions of current legislation. The user shall also consider the ignition temperatures of gases, vapours or mists and clouds of combustible dust in air in the area of use.



CHEMICAL COMPATIBILITY

The **type of liquid, temperature and working environment** are factors to be considered when deciding on the best choice of construction materials for the pump and its **correct chemical compatibility**. Some examples are given in the following table:

SUBSTANCE	Polypropylene	PVDF ECTFE (Halair®)	Aluminium	Stainless Steel AISI 316	NBR (Perbunan®)	EPDM (Dutral®)	PTFE (Teflon®)	PPS-V (Ryton®)	FPM (Viton®)	Santoprene®	PE-UHMW (Poleszene®)
Acetaldehyde	A1	D	B	A	D	A	A	A	D	-	B
Acetamide	A1	C	A	A	A	A	A	A	B	-	-
Vinyl acetate	B1	A2	A1	B	D	B2	A2	-	A1	-	D
Acetylene	A1	A	A	A	B	A	A	A	A	-	-
Vinegar	A	B	D	A	B	A	A	A	A	-	A
Acetone	A	D	A	A	D	A	A	A	D	A1	A2
Fatty acids	A	A	A	A	B	D	A	-	A	D	A

A = very good
 B = good
 C = poor, not recommended
 D = severe etching, not recommended
 - = information not available
 1 = satisfactory up to 22°C (72°F)
 2 = satisfactory up to 48°C (120°F)

For further information, please do not hesitate to contact DEBEM's technical service department. We have obtained this information from reliable sources.

Debem has not performed any form of testing in this regard and therefore accepts no liability for the accuracy of the details provided.



Example illustrating the graphic reading of the performance

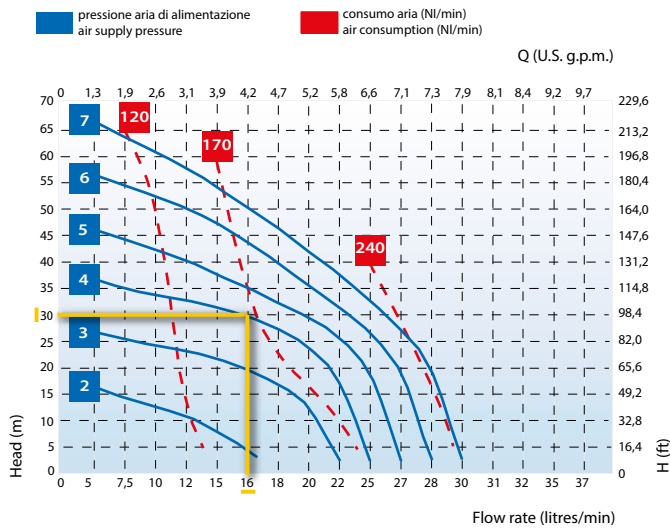

Flow rate 16 l/min – Pump head 30 m/ca
 Supply pressure: 4 bar
 Air consumption: 170 NI/min

Compressor table

Air consumption NI/min	Power approximated (compressor) HP	PUMP TYPE	DISPLACEMENT
50	0,5	MIDGETBOX	3,2 cc
100	1	CUBIC 15	10,3 cc
200	2	MICROBOXER	30 cc
250	2,5	MINIBOXER/B50	67 cc
350	3,5	BOXER 80/81	100 cc
450	4,5	BOXER 100	222 cc
550	5,5	BOXER 150	340 cc
850	8,5	BOXER 251	522 cc
1000	10	BOXER 502/522	1.825 cc
1500	15	BOXER 503	1.852 cc
2000	20	EQUAFLUX 51	8 cc
3500	30	EQUAFLUX 100	15 cc
4000	40	EQUAFLUX 200	100 cc
		EQUAFLUX 302/303	320 cc

The actual power absorbed by the compressor is approximately 70% of the value indicated in the table. It is recommended to use a compressor with a tank.

Displacement table

referred to the stroke complete with membrane

Please note: when operating at FREE AIR FLOW conditions, the actual flow rate is much higher than the ratio between the number of cycles detected and the displacement due to the momentum.

Decrease in the flow rate relating to the viscosity

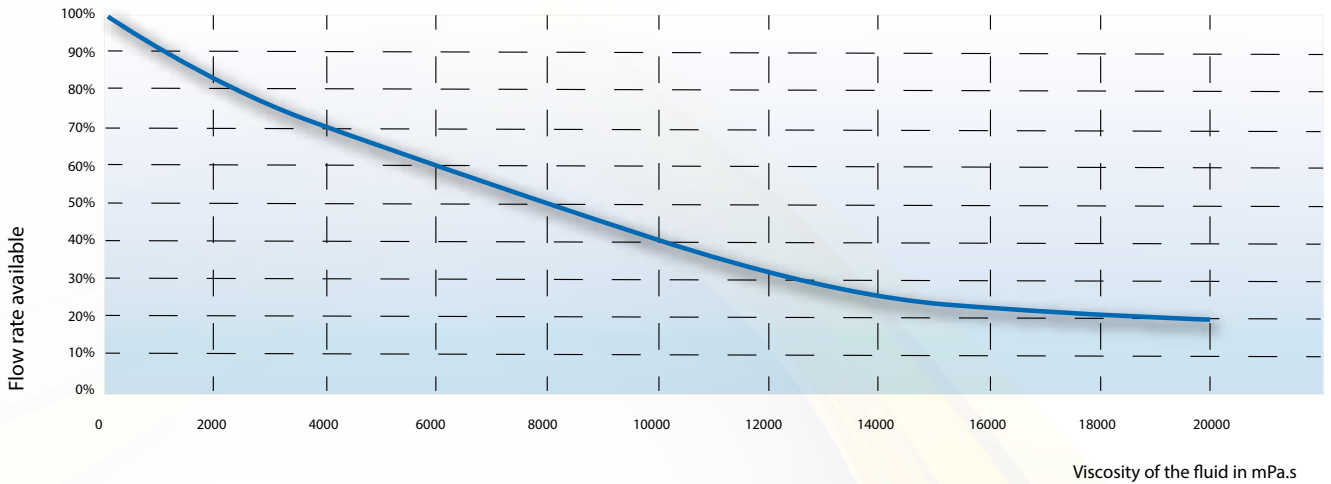

Boxer Pumps – Loss of flow capacity on the suction height

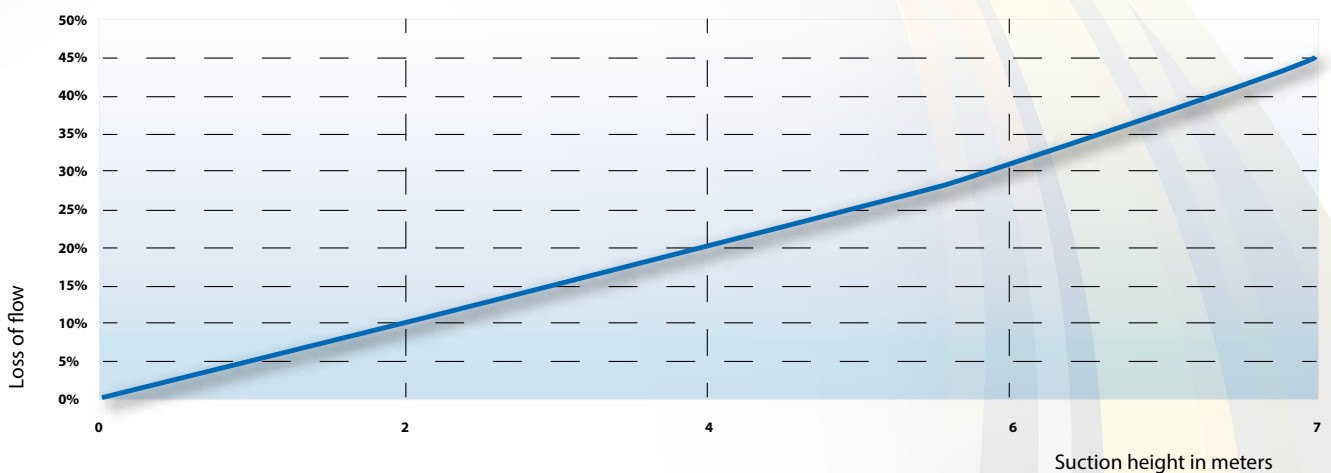

Loss of flow capacity in percentage relating to the suction height.

BOXER diaphragm pumps are characterized by exceptional performance, power and strength, making them ideal for pumping liquids with high apparent viscosity even if containing suspended solids. The **stall-prevention** pneumatic system assures a safe pump running and it does **not need lubricated air**.

Self-priming dry capacity even with considerable suction head, **fine tuning of speed** without pressure loss and the **possibility of dry operation without suffering damage** mean that these pumps offer unrivalled versatility. In addition, the huge choice of construction materials allows selection of optimum chemical compatibility with the fluid and/or environment without neglecting the temperature range. They are specifically designed for **demanding applications with high humidity or in potentially explosive atmospheres (ATEX certification)**.

Intake/delivery connections G 1/2" f (*) - flow rate 30 l/min

Construction materials: PP - PVDF - Alu - Aisi 316



DIAPHRAGM PUMPS



PP



PVDF



Alu



Aisi 316

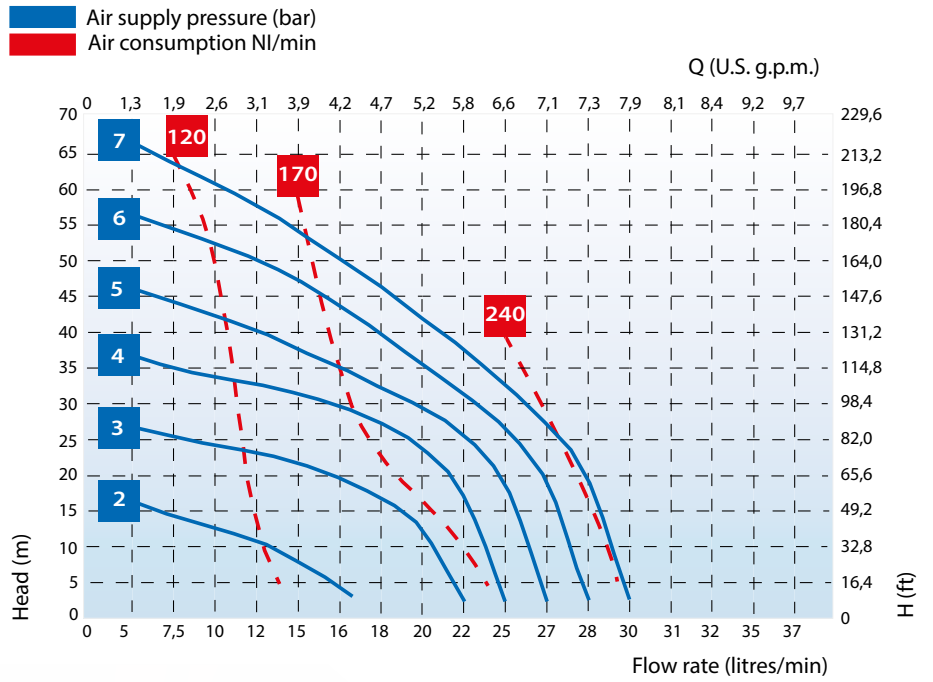

*The curves and performance values refer to pumps with submerged suction and a free delivery outlet with water at 20°C, and vary according to the construction material. ** The value depends on the configuration of the pump.

Intake/delivery connections	G 1/2" f (*)		
Air connection	G 1/4" f		
Max. self-priming capacity**	6 m		
Flow rate max*	30 l/min		
Max. head*	70 m		
Max. air supply pressure	7 bar		
Max. diameter of passing solids	2 mm		
Construction materials and net weight	PP	1,6 Kg	65°C Max Temp.
	PVDF	1,9 Kg	95°C Max Temp.
	Alu	2 Kg	95°C Max Temp.
	Aisi 316	3,8 Kg	95°C Max Temp.

(*) NPT connections on request

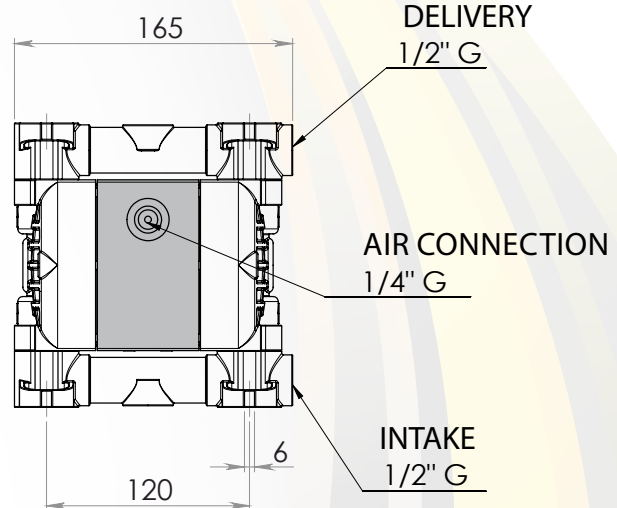
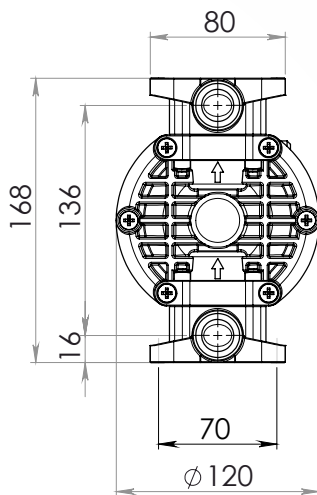

The dimensions shown are in mm

MINIBOXER - BOXER 50

 STANDARD: II 3/3 GD c IIB T135°C (zone 2)
CONDUCT: II 2/2 GD c IIB T135°C (zone 1)



DIAPHRAGM PUMPS

BOXER diaphragm pumps are characterized by exceptional performance, power and strength, making them ideal for pumping liquids with high apparent viscosity even if containing suspended solids. The **stall-prevention** pneumatic system assures a safe pump running and it does **not need lubricated air**.

Self-priming dry capacity even with considerable suction head, **fine tuning of speed** without pressure loss and the **possibility of dry operation without suffering damage** mean that these pumps offer unrivalled versatility. In addition, the huge choice of construction materials allows selection of optimum chemical compatibility with the fluid and/or environment without neglecting the temperature range. They are specifically designed for **demanding applications with high humidity or in potentially explosive atmospheres (ATEX certification)**.

Intake/delivery connections G 1/2" f o DN 15 (*) - flow rate 50 l/min

Construction materials: PP - PVDF - Alu - Aisi 316





PP



PVDF



Alu



Aisi 316

■ Air supply pressure (bar)
■ Air consumption NI/min

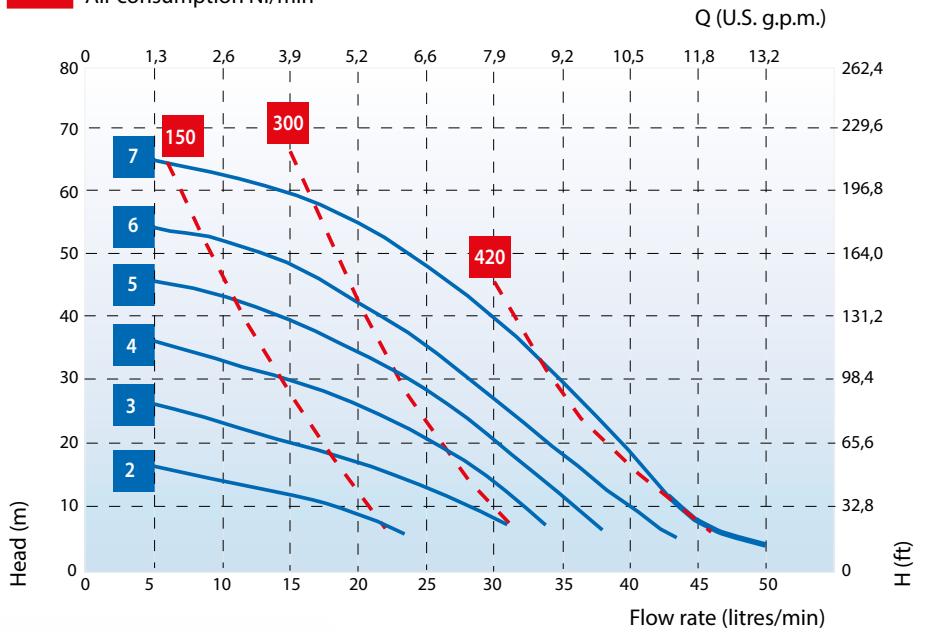

*The curves and performance values refer to pumps with submerged suction and a free delivery outlet with water at 20°C, and vary according to the construction material. ** The value depends on the configuration of the pump.

Intake/delivery connections	G 1/2" f o DN 15 (*)		
Air connection	G 3/8" f		
Max. self-priming capacity**	5 m		
Flow rate max*	50 l/min		
Max. head*	70 m		
Max. air supply pressure	7 bar		
Max. diameter of passing solids	4 mm		
Construction materials and net weight	PP	3,6 Kg	65°C Max Temp.
	PVDF	4,2 Kg	95°C Max Temp.
	Alu	4 Kg	95°C Max Temp.
	Aisi 316	6,5 Kg	95°C Max Temp.

(*) NPT connections on request

B50

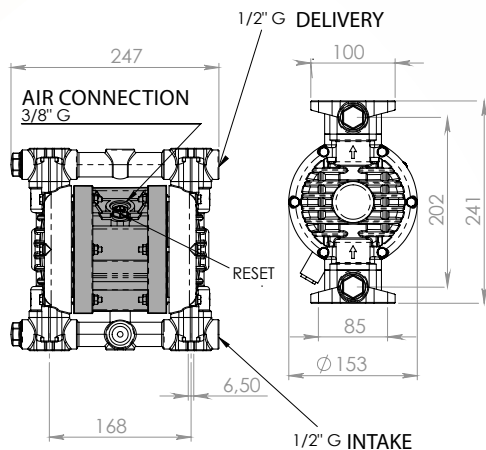

MINIBOXER Aisi 316

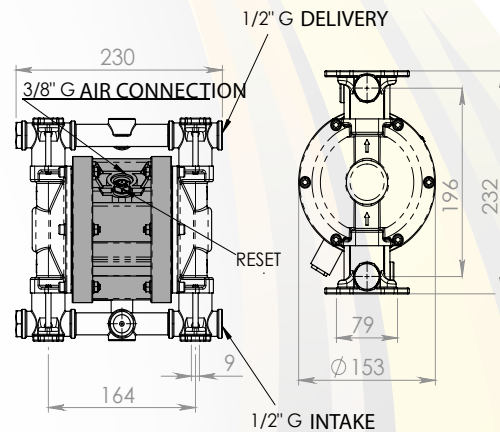

The dimensions shown are in mm

BOXER 80/81

 **STANDARD:** II 3/3 GD c IIB T135°C (zone 2)
CONDUCT: II 2/2 GD c IIB T135°C (zone 1)



BOXER diaphragm pumps are characterized by exceptional performance, power and strength, making them ideal for pumping liquids with high apparent viscosity even if containing suspended solids. The **stall-prevention** pneumatic system assures a safe pump running and it does **not need lubricated air**.

Self-priming dry capacity even with considerable suction head, **fine tuning of speed** without pressure loss and the **possibility of dry operation without suffering damage** mean that these pumps offer unrivalled versatility. In addition, the huge choice of construction materials allows selection of optimum chemical compatibility with the fluid and/or environment without neglecting the temperature range. They are specifically designed for **demanding applications with high humidity or in potentially explosive atmospheres (ATEX certification)**.

DIAPHRAGM PUMPS

Intake/delivery connections G 1" f o DN 25 (*) - flow rate 100 l/min

Construction materials: PP - PVDF - Alu - Aisi 316



DIAPHRAGM PUMPS



PP



PVDF



Alu



Aisi 316

■ Air supply pressure (bar)
■ Air consumption NI/min

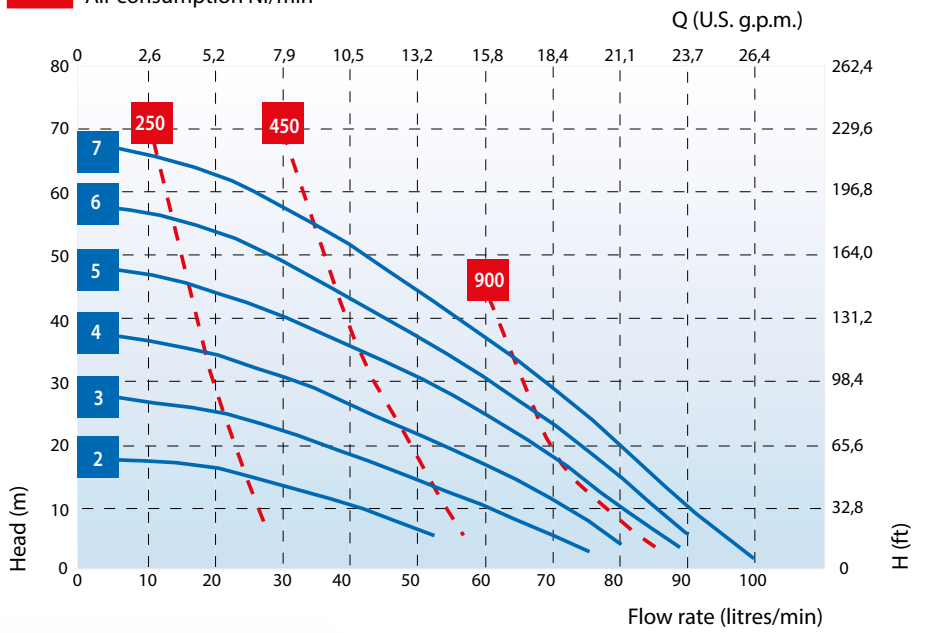

*The curves and performance values refer to pumps with submerged suction and a free delivery outlet with water at 20°C, and vary according to the construction material. ** The value depends on the configuration of the pump.

Intake/delivery connections	G 1" fo DN 25 (*)		
Air connection	G 3/8" f		
Max. self-priming capacity**	6 m		
Flow rate max*	100 l/min		
Max. head*	70 m		
Max. air supply pressure	7 bar		
Max. diameter of passing solids	4 mm		
Construction materials and net weight	PP	5 Kg	65°C Max Temp.
	PVDF	6,5 Kg	95°C Max Temp.
	Alu	6,5 Kg	95°C Max Temp.
	Aisi 316	10,5 Kg	95°C Max Temp.

(*) NPT connections on request

B80

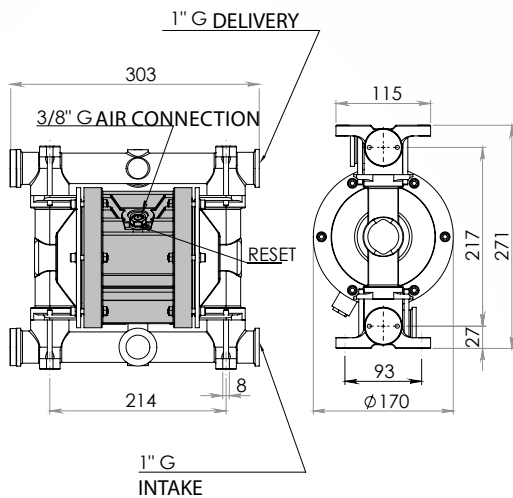

B81

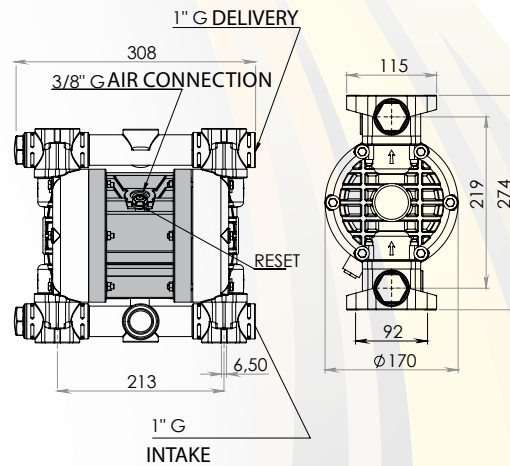

The dimensions shown are in mm

BOXER 100

 **STANDARD:** II 3/3 GD c IIB T135°C (zone 2)
CONDUCT: II 2/2 GD c IIB T135°C (zone 1)



BOXER diaphragm pumps are characterized by exceptional performance, power and strength, making them ideal for pumping liquids with high apparent viscosity even if containing suspended solids. The **stall-prevention** pneumatic system assures a safe pump running and it does **not need lubricated air**.

Self-priming dry capacity even with considerable suction head, **fine tuning of speed** without pressure loss and the **possibility of dry operation without suffering damage** mean that these pumps offer unrivalled versatility. In addition, the huge choice of construction materials allows selection of optimum chemical compatibility with the fluid and/or environment without neglecting the temperature range. They are specifically designed for **demanding applications with high humidity or in potentially explosive atmospheres (ATEX certification)**.

DIAPHRAGM PUMPS

Intake/delivery connections G 1" f o DN 25 (*) - flow rate 150 l/min

Construction materials: PP - PVDF - Alu - Aisi 316



DIAPHRAGM PUMPS

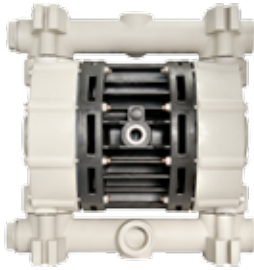

PP



PVDF



Alu

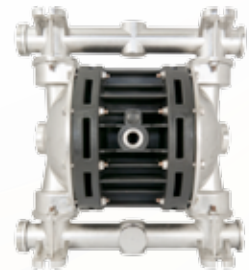

Aisi 316

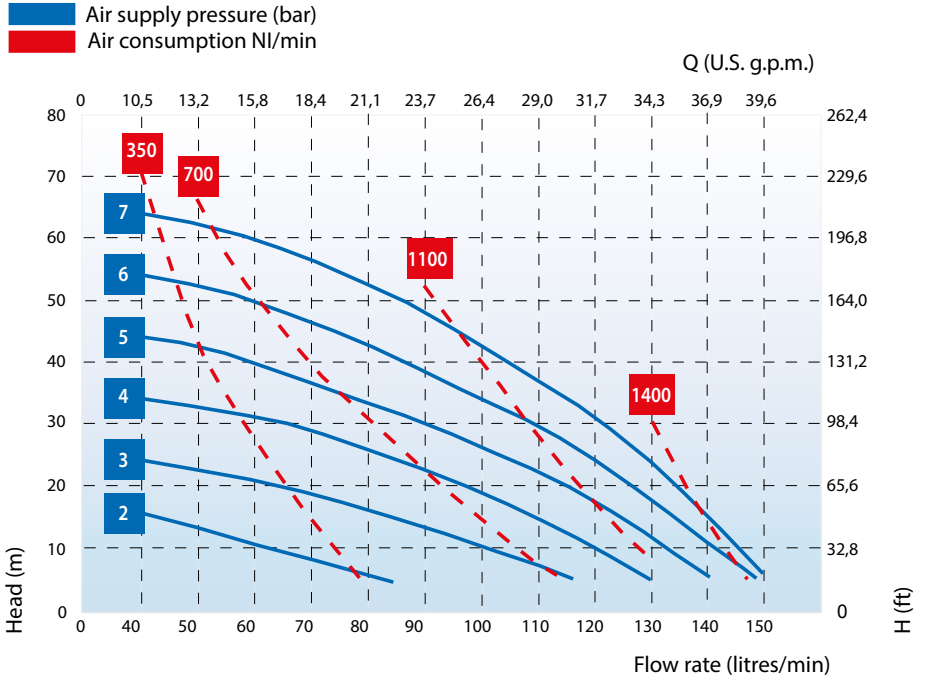

*The curves and performance values refer to pumps with submerged suction and a free delivery outlet with water at 20°C, and vary according to the construction material. ** The value depends on the configuration of the pump.

Intake/delivery connections	G 1" f o DN 25 (*)		
Air connection	G 3/8" f		
Max. self-priming capacity**	5 m		
Flow rate max*	150 l/min		
Max. head*	70 m		
Max. air supply pressure	7 bar		
Max. diameter of passing solids	4 mm		
Construction materials and net weight	PP	7,5 Kg	65°C Max Temp.
	PVDF	8,5 Kg	95°C Max Temp.
	Alu	8,2 Kg	95°C Max Temp.
	Aisi 316	11 Kg	95°C Max Temp.

(*) NPT connections on request

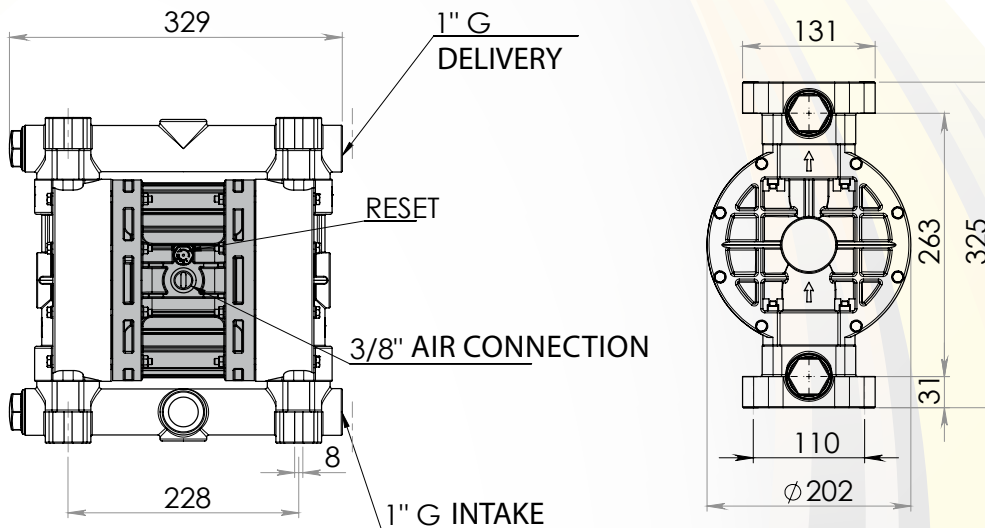

The dimensions shown are in mm

BOXER 150

 **STANDARD:** II 3/3 GD c IIB T135°C (zone 2)
CONDUCT: II 2/2 GD c IIB T135°C (zone 1)



BOXER diaphragm pumps are characterized by exceptional performance, power and strength, making them ideal for pumping liquids with high apparent viscosity even if containing suspended solids. The **stall-prevention** pneumatic system assures a safe pump running and it does **not need lubricated air**.

Self-priming dry capacity even with considerable suction head, **fine tuning of speed** without pressure loss and the **possibility of dry operation without suffering damage** mean that these pumps offer unrivalled versatility. In addition, the huge choice of construction materials allows selection of optimum chemical compatibility with the fluid and/or environment without neglecting the temperature range. They are specifically designed for **demanding applications with high humidity or in potentially explosive atmospheres (ATEX certification)**.

DIAPHRAGM PUMPS

Intake/delivery connections G 1" 1/4 f o DN 32 (*) - flow rate 220 l/min

Construction materials: PP - PVDF - Alu - Aisi 316



DIAPHRAGM PUMPS

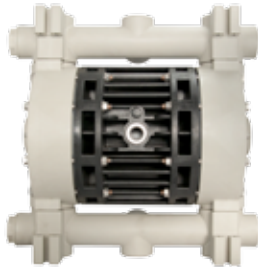

PP



PVDF

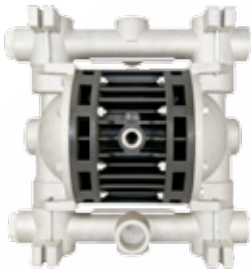

Alu

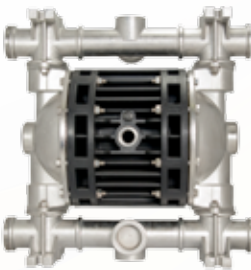

Aisi 316

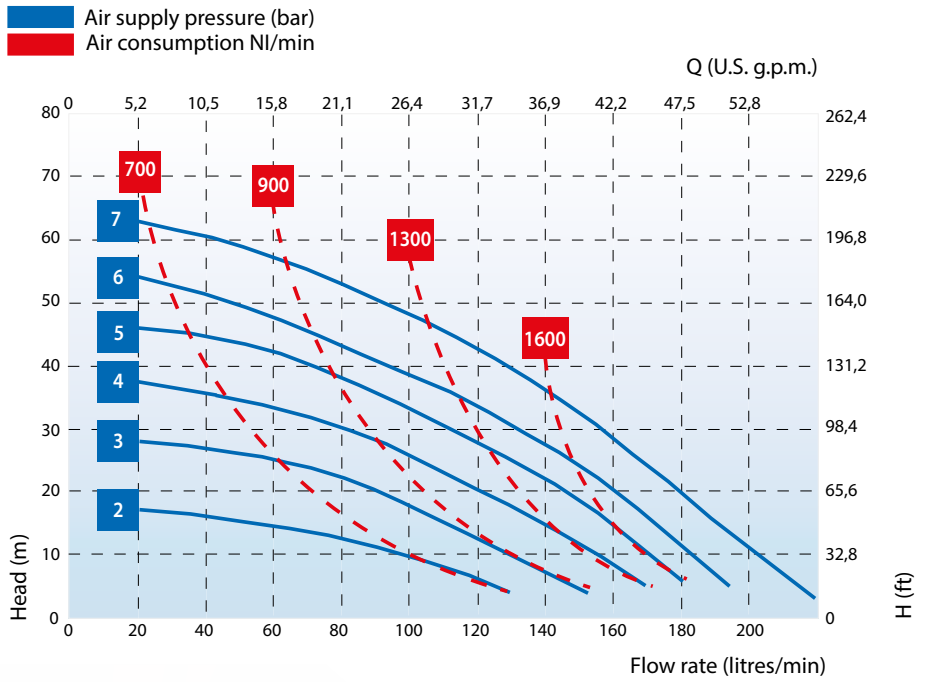

*The curves and performance values refer to pumps with submerged suction and a free delivery outlet with water at 20°C, and vary according to the construction material. ** The value depends on the configuration of the pump.

Intake/delivery connections	G 1" 1/4 f o DN 32 (*)		
Air connection	G 1/2" f		
Max. self-priming capacity**	6 m		
Flow rate max*	220 l/min		
Max. head*	70 m		
Max. air supply pressure	7 bar		
Max. diameter of passing solids	5 mm		
Construction materials and net weight	PP	12 Kg	65°C Max Temp.
	PVDF	14 Kg	95°C Max Temp.
	Alu	16 Kg	95°C Max Temp.
	Aisi 316	21 Kg	95°C Max Temp.

(*) NPT connections on request

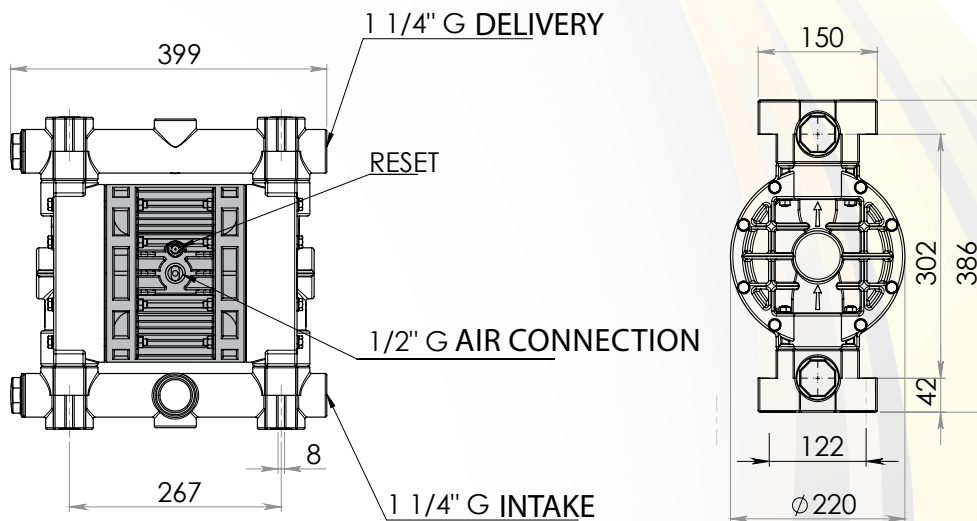

The dimensions shown are in mm

BOXER 251

 **STANDARD:** II 3/3 GD c IIB T135°C (zone 2)
CONDUCT: II 2/2 GD c IIB T135°C (zone 1)



BOXER diaphragm pumps are characterized by exceptional performance, power and strength, making them ideal for pumping liquids with high apparent viscosity even if containing suspended solids. The **stall-prevention** pneumatic system assures a safe pump running and it does **not need lubricated air**.

Self-priming dry capacity even with considerable suction head, **fine tuning of speed** without pressure loss and the **possibility of dry operation without suffering damage** mean that these pumps offer unrivalled versatility. In addition, the huge choice of construction materials allows selection of optimum chemical compatibility with the fluid and/or environment without neglecting the temperature range. They are specifically designed for **demanding applications with high humidity or in potentially explosive atmospheres (ATEX certification)**.

DIAPHRAGM PUMPS

Intake/delivery connections G 1" 1/2 f o DN 40 (*) - flow rate 340 l/min

Construction materials: PP - PVDF - Alu - Aisi 316

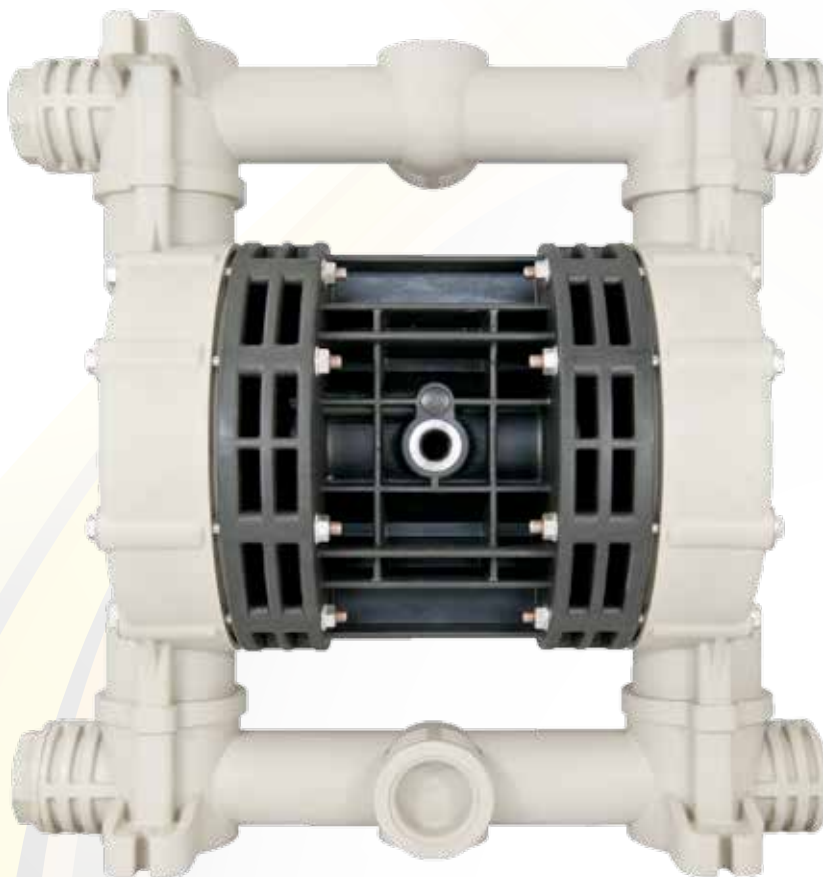

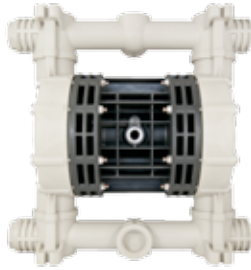

PP



PVDF

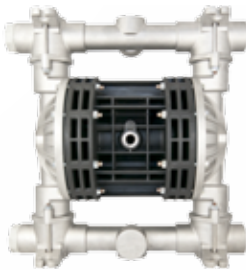

Alu

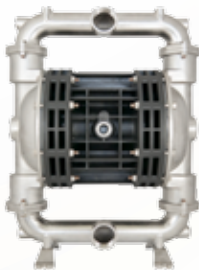

Aisi 316

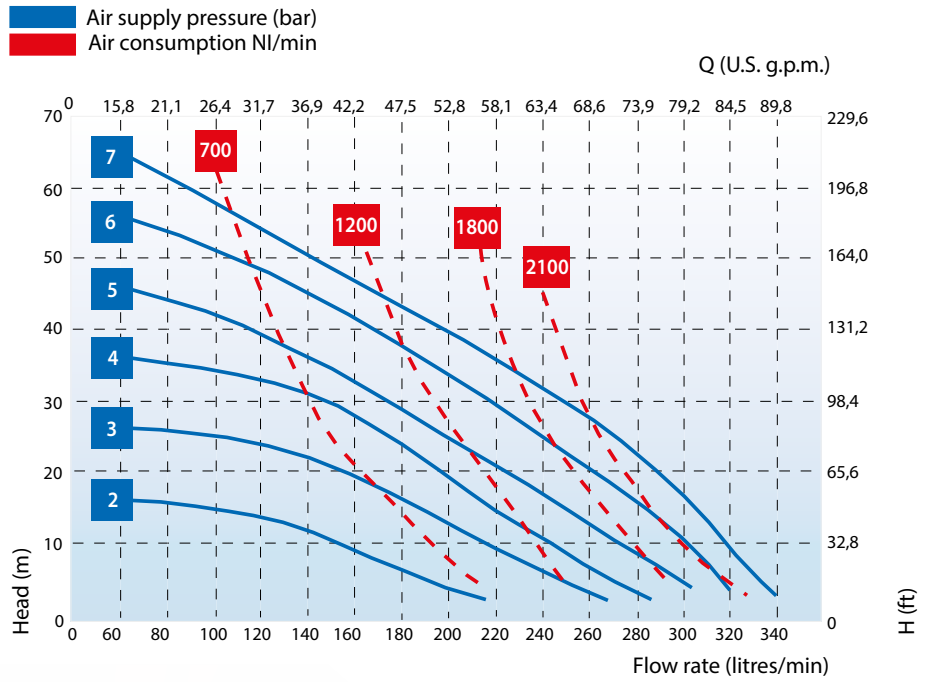

*The curves and performance values refer to pumps with submerged suction and a free delivery outlet with water at 20°C, and vary according to the construction material. ** The value depends on the configuration of the pump.

Intake/delivery connections	G 1" 1/2 f o DN 40 (*)		
Air connection	G 1/2" f		
Max. self-priming capacity**	6 m		
Flow rate max*	340 l/min		
Max. head*	70 m		
Max. air supply pressure	7 bar		
Max. diameter of passing solids	6 mm		
Construction materials and net weight	PP	16 Kg	65°C Max Temp.
	PVDF	20 Kg	95°C Max Temp.
	Alu	21 Kg	95°C Max Temp.
	Aisi 316	32 Kg	95°C Max Temp.

(*) NPT connections on request

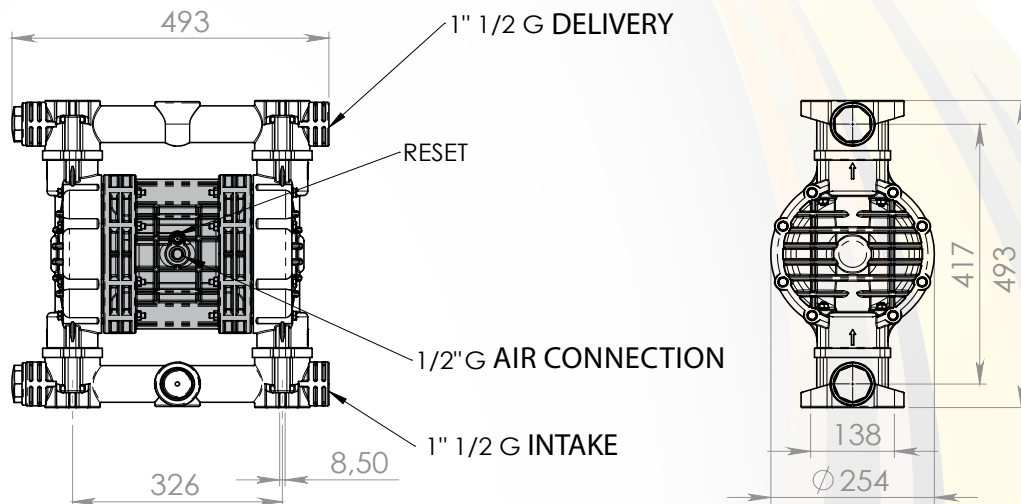

The dimensions shown are in mm

BOXER 522

 **STANDARD:** II 3/3 GD c IIB T135°C (zone 2)
CONDUCT: II 2/2 GD c IIB T135°C (zone 1)



DIAPHRAGM PUMPS

BOXER diaphragm pumps are characterized by exceptional performance, power and strength, making them ideal for pumping liquids with high apparent viscosity even if containing suspended solids. The **stall-prevention** pneumatic system assures a safe pump running and it does **not need lubricated air**.

Self-priming dry capacity even with considerable suction head, **fine tuning of speed** without pressure loss and the **possibility of dry operation without suffering damage** mean that these pumps offer unrivalled versatility. In addition, the huge choice of construction materials allows selection of optimum chemical compatibility with the fluid and/or environment without neglecting the temperature range. They are specifically designed for **demanding applications with high humidity or in potentially explosive atmospheres (ATEX certification)**.

Intake/delivery connections G 2" f o DN 50 (*) - flow rate 650 l/min

Construction materials: PP - PVDF



DIAPHRAGM PUMPS

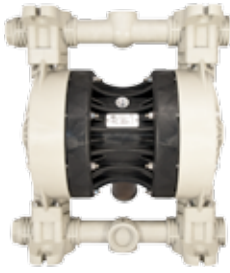

PP



PVDF

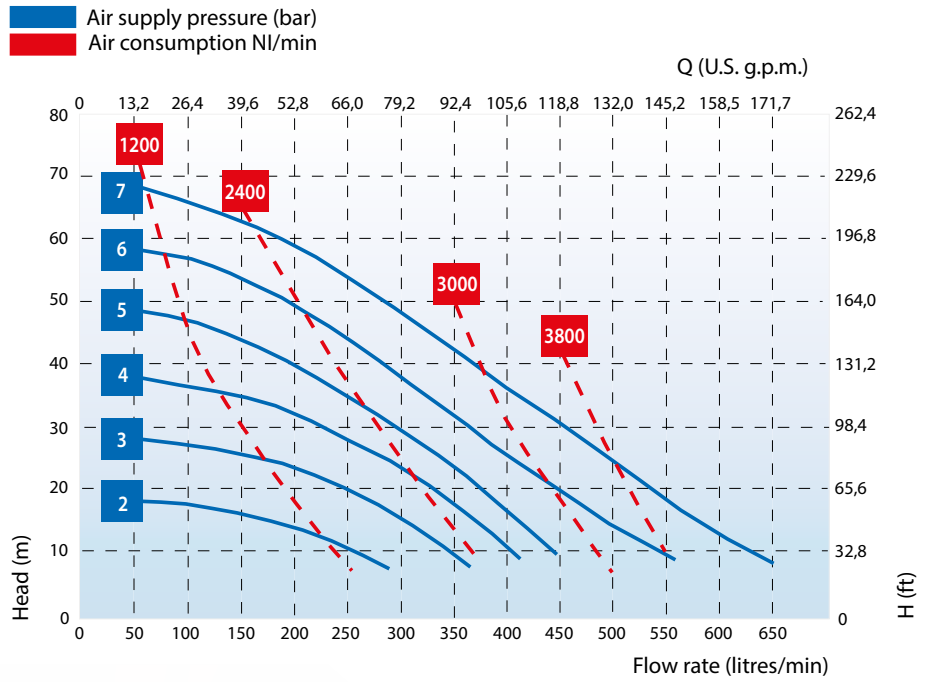

*The curves and performance values refer to pumps with submerged suction and a free delivery outlet with water at 20°C, and vary according to the construction material. ** The value depends on the configuration of the pump.

Intake/delivery connections	G 2" f o DN 50 (*)		
Air connection	G 1/2" f		
Max. self-priming capacity**	6 m		
Flow rate max*	650 l/min		
Max. head*	70 m		
Max. air supply pressure	7 bar		
Max. diameter of passing solids	8 mm		
Construction materials and net weight	PP	38 Kg	65°C Max Temp.
	PVDF	45 Kg	95°C Max Temp.

(*) NPT connections on request

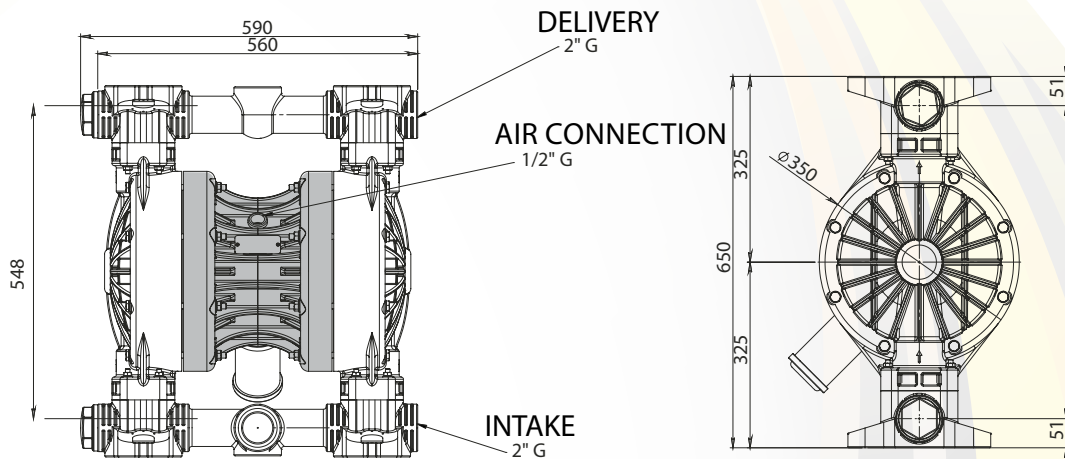

The dimensions shown are in mm

BOXER 502

 **STANDARD:** II 3/3 GD c IIB T135°C (zone 2)
CONDUCT: II 2/2 GD c IIB T135°C (zone 1)



DIAPHRAGM PUMPS

BOXER diaphragm pumps are characterized by exceptional performance, power and strength, making them ideal for pumping liquids with high apparent viscosity even if containing suspended solids. The **stall-prevention** pneumatic system assures a safe pump running and it does **not need lubricated air**.

Self-priming dry capacity even with considerable suction head, **fine tuning of speed** without pressure loss and the **possibility of dry operation without suffering damage** mean that these pumps offer unrivalled versatility. In addition, the huge choice of construction materials allows selection of optimum chemical compatibility with the fluid and/or environment without neglecting the temperature range. They are specifically designed for **demanding applications with high humidity or in potentially explosive atmospheres (ATEX certification)**.

Intake/delivery connections G 2" f o DN 50 (*) - flow rate 650 l/min

Construction materials: Alu - Aisi 316





Alu



Aisi 316

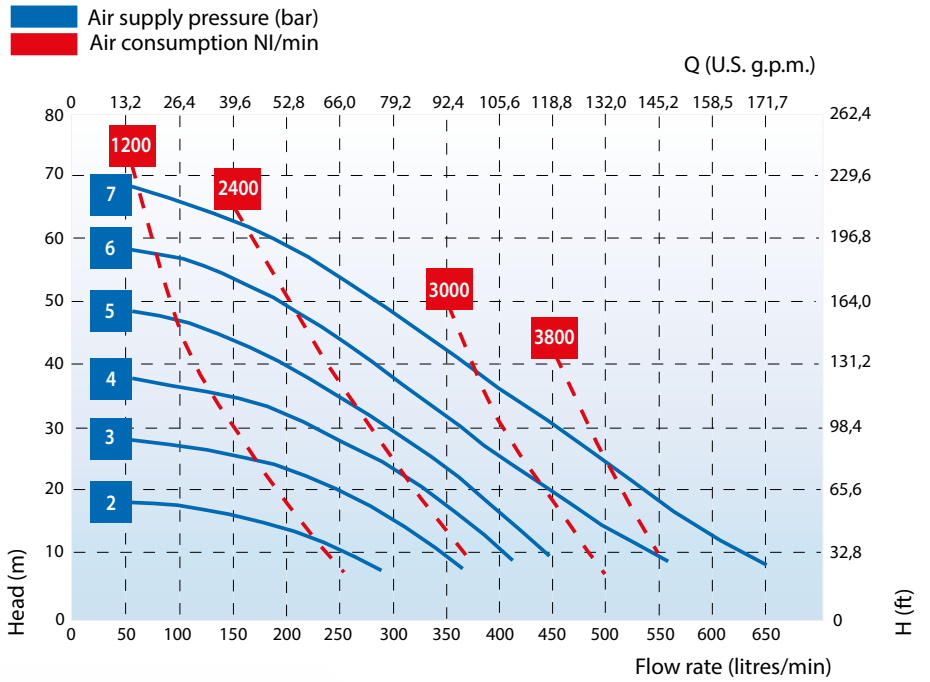

*The curves and performance values refer to pumps with submerged suction and a free delivery outlet with water at 20°C, and vary according to the construction material. ** The value depends on the configuration of the pump.

Intake/delivery connections	G 2" f o DN 50 (*)		
Air connection	G 1/2" f		
Max. self-priming capacity**	6 m		
Flow rate max*	650 l/min		
Max. head*	70 m		
Max. air supply pressure	7 bar		
Max. diameter of passing solids	8 mm		
Construction materials and net weight	Alu	49 Kg	95°C Max Temp.
	Aisi 316	54 Kg	95°C Max Temp.

(*) NPT connections on request

Aisi 316

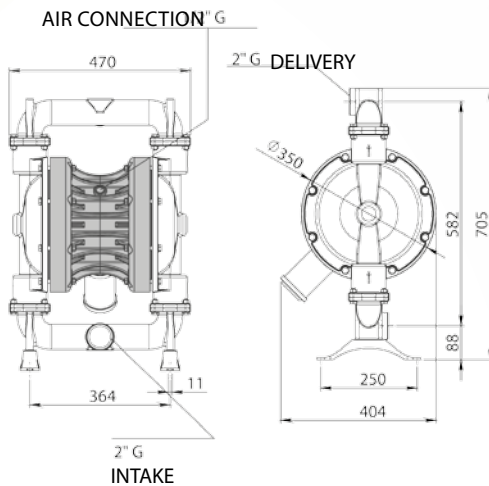

Alu

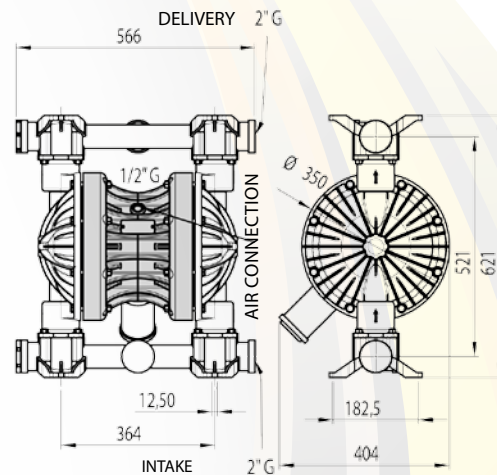

The dimensions shown are in mm

BOXER 503 plastic

 STANDARD: II 3/3 GD c IIB T135°C (zone 2)
CONDUCT: II 2/2 GD c IIB T135°C (zone 1)



DIAPHRAGM PUMPS

BOXER diaphragm pumps are characterized by exceptional performance, power and strength, making them ideal for pumping liquids with high apparent viscosity even if containing suspended solids. The **stall-prevention** pneumatic system assures a safe pump running and it does **not need lubricated air**.

Self-priming dry capacity even with considerable suction head, **fine tuning of speed** without pressure loss and the **possibility of dry operation without suffering damage** mean that these pumps offer unrivalled versatility. In addition, the huge choice of construction materials allows selection of optimum chemical compatibility with the fluid and/or environment without neglecting the temperature range. They are specifically designed for **demanding applications with high humidity or in potentially explosive atmospheres (ATEX certification)**.

Intake/delivery connections G 3" f o DN 80 (*) - flow rate 900 l/min

Construction materials: PP - PVDF



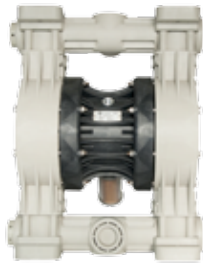

PP



PVDF

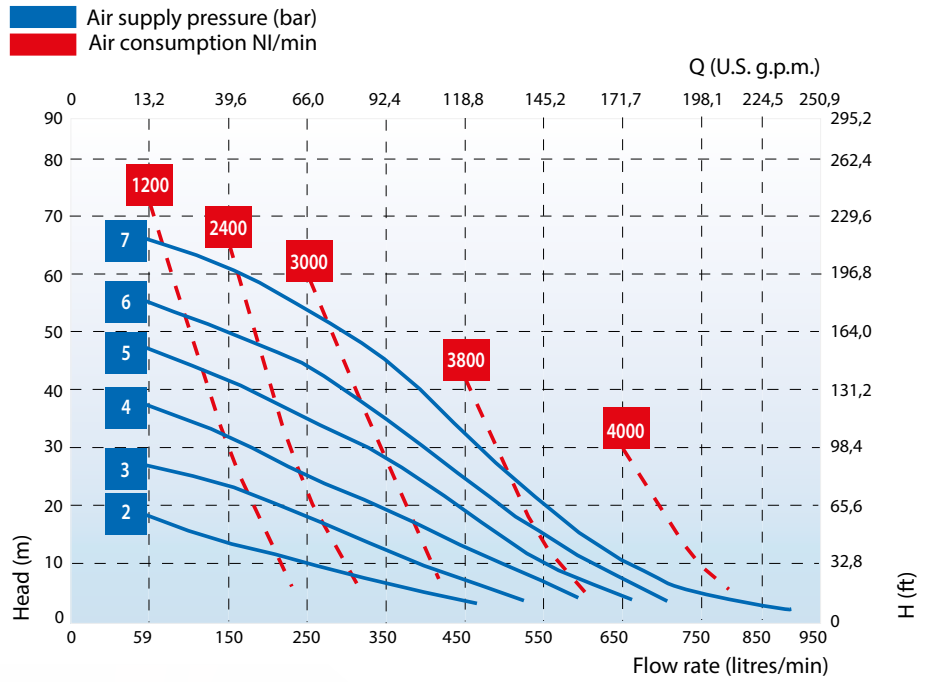

*The curves and performance values refer to pumps with submerged suction and a free delivery outlet with water at 20°C, and vary according to the construction material. ** The value depends on the configuration of the pump.

Intake/delivery connections	G 3" f o DN 80 (*)		
Air connection	G 3/4" f		
Max. self-priming capacity**	5 m		
Flow rate max*	900 l/min		
Max. head*	70 m		
Max. air supply pressure	7 bar		
Max. diameter of passing solids	10 mm		
Construction materials and net weight	PP	50 Kg	65°C Max Temp.
	PVDF	67 Kg	95°C Max Temp.

(*) NPT connections on request

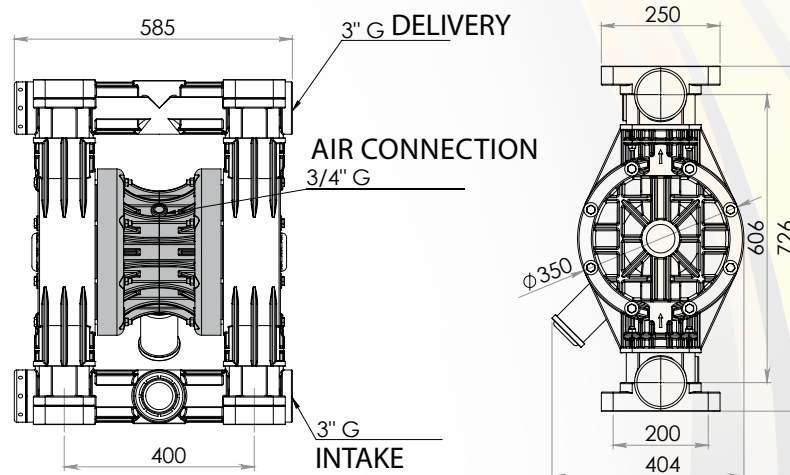

The dimensions shown are in mm

BOXER 503 metal

 STANDARD: II 3/3 GD c IIB T135°C (zone 2)
CONDUCT: II 2/2 GD c IIB T135°C (zone 1)



DIAPHRAGM PUMPS

BOXER diaphragm pumps are characterized by exceptional performance, power and strength, making them ideal for pumping liquids with high apparent viscosity even if containing suspended solids. The **stall-prevention** pneumatic system assures a safe pump running and it does **not need lubricated air**.

Self-priming dry capacity even with considerable suction head, **fine tuning of speed** without pressure loss and the **possibility of dry operation without suffering damage** mean that these pumps offer unrivalled versatility. In addition, the huge choice of construction materials allows selection of optimum chemical compatibility with the fluid and/or environment without neglecting the temperature range. They are specifically designed for **demanding applications with high humidity or in potentially explosive atmospheres (ATEX certification)**.

Intake/delivery connections G 3" f o DN 80 (*) - flow rate 900 l/min

Construction materials: Alu - Aisi 316





Alu



Aisi 316

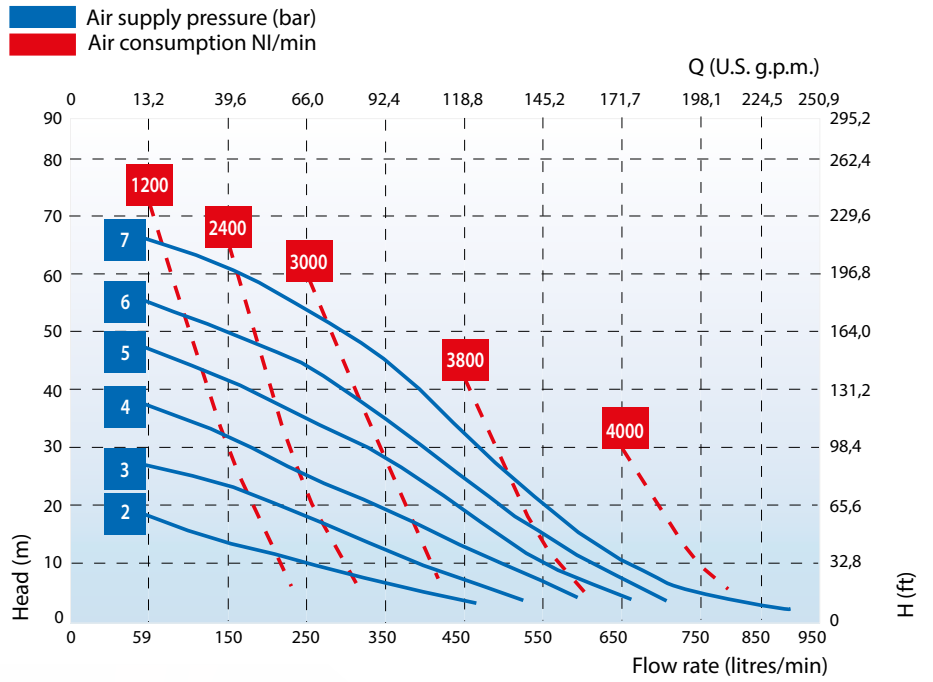

*The curves and performance values refer to pumps with submerged suction and a free delivery outlet with water at 20°C, and vary according to the construction material. ** The value depends on the configuration of the pump.

Intake/delivery connections	G 3" f o DN 80 (*)		
Air connection	G 3/4" f		
Max. self-priming capacity**	5 m		
Flow rate max*	900 l/min		
Max. head*	70 m		
Max. air supply pressure	7 bar		
Max. diameter of passing solids	10 mm		
Construction materials and net weight	Alu	66 Kg	95°C Max Temp.
	Aisi 316	71 Kg	95°C Max Temp.

(*) NPT connections on request

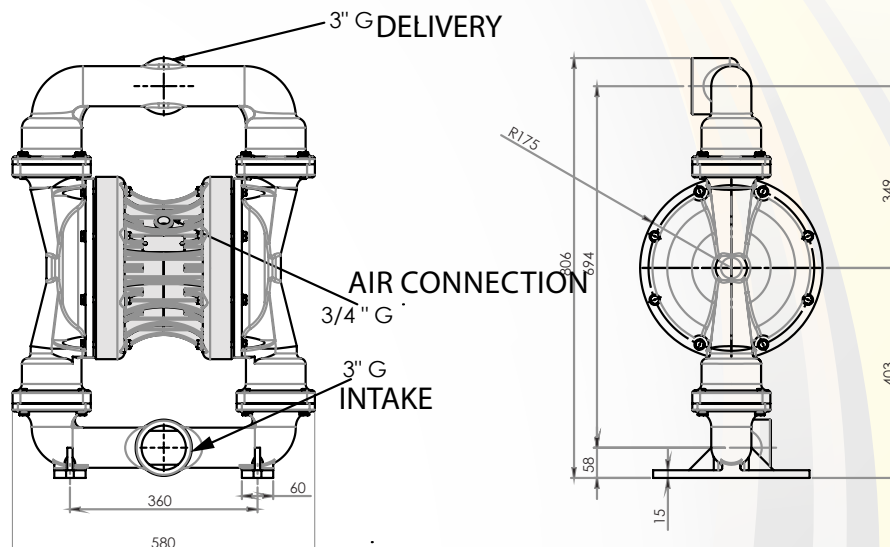

The dimensions shown are in mm